

**SUPER 8 50**

Scooter

E5

# Owner's Manual





## **WARNING**

To avoid damage from the electronic fuel injection system, do not remove or install the battery when the ignition switch is in the " ON " position.

The long-term storage of the vehicle could cause fuel and engine oil deterioration and probably get into a non-start situation.

Service more frequently when operating in severe conditions such as dusty area, high speed riding, frequent start and stop or extreme riding habit.

Make sure to keep away from any flammable materials such as dry grasses or leaves, avoid them in contact with the exhaust pipe or muffler when parking the vehicle.

## Read this Manual carefully

This Owner's Manual contains important information on safety, operation and maintenance of KYMCO Super 8 50. Anyone who is going to ride should carefully read and understand the contents of this manual before riding. For personal safety, understand and follow all of the warnings contained in this Owner's Manual and the labels attached on vehicle. This Owner's Manual should be considered a permanent part of the vehicle, keep it with the scooter. ON-ROAD USE ONLY for this scooter.

**Particularly important information is provided in this manual by the following symbols and signal words:**



The SAFETY ALERT symbol means ATTENTION! BE ALERT! YOUR SAFETY CAN BE AFFECTED.



**WARNING**

Failure to follow these instructions can result in severe injury or death.



**CAUTION**

These instructions point out the special precautions must be followed to avoid damage.

**NOTE:**

The NOTE indicates the additional important information.

# Identification Numbers Record

Vehicle Identification Number (VIN)

Engine Serial Number (ESN)

Record the Vehicle Identification Number ① or ②, Engine Serial Number ③, in the blanks above for a reference to assist you in ordering parts from the authorized KYMCO dealer or in case the vehicle is stolen.

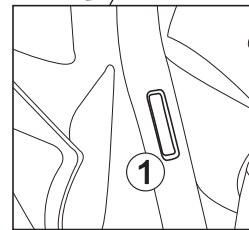
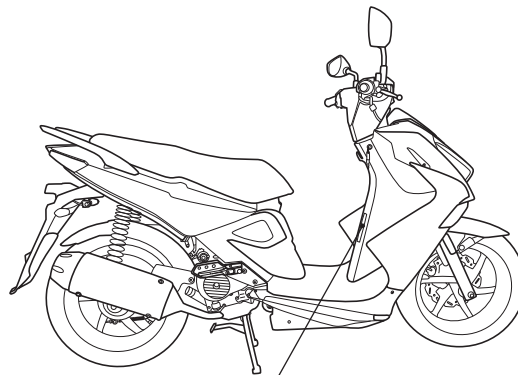
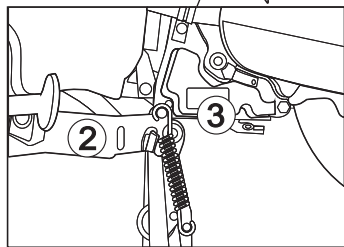
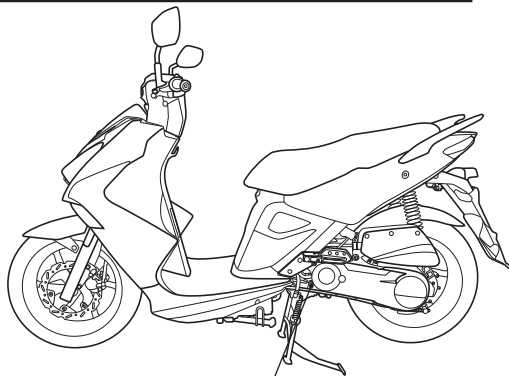

# TABLE OF CONTENTS

<b>SECTION 1–SAFETY INTRODUCTION...1</b>	<b>SECTION 4–MAINTENANCE.....24</b>
Forward.....1	Maintenance Schedule.....24
Scooter Safety.....2	Engine Oil.....28
Accessories & Modifications.....4	Engine Oil Replacement.....29
Locations of Parts & Controls.....5	Transmission Fluid Change .....30
<b>SECTION 2–CONTROLS &amp; FEATURES.....8</b>	Air Filter Element Change .....31
Ignition Switch.....8	Throttle Operation.....32
Instruments.....9	Spark Plug.....33
Passenger foot pegs.....13	Brake Fluid Level Inspection.....34
Right-hand Handlebar Switch.....14	Brake Pad Inspection . . .35
Left-hand Handlebar Switch.....15	Battery.....37
Fuel Recommendation.....16	Fuse.....38
Seat.....17	Tires.....39
Helmet Holder and Hook.....18	Tires Inspection.....40
Suspension.....19	Clean the Vehicle.....41
<b>SECTION 3–OPERATION.....20</b>	Crankcase Blow-by Drain.....42
Pre-ride Inspection.....20	Storage.....43
Break-in.....21	<b>EMISSION CONTROL.....44</b>
Starting the Engine.....22	<b>MAINTENANCE RECORD.....45</b>
	<b>SPECIFICATIONS.....47</b>

# **SECTION 1 - FORWARD & SAFETY INTRODUCTION**

Thanks for purchasing this KYMCO **Super 8 50**, and welcome to the KYMCO family. Please read this owner's manual carefully before riding so that you will be thoroughly familiar with the proper operation of controls, features, capabilities, and limitations.

To ensure a long, trouble-free life for using the vehicle, provide it with the proper care and maintenance as described in this manual.

For replacement parts and accessories, you should always use genuine KYMCO products, as they have been specially designed for the vehicle and manufactured to meet the standards. Keep this owner's manual with the scooter at all times so that you can refer to it whenever you need information. This manual should be considered a permanent part of the scooter and should remain with the vehicle when it is sold.

All information, illustrations, photographs and specifications contained in this manual are based on the latest product information available at the time of publication. Due to improvements or other changes, there may be slightly different from the vehicle. KYMCO reserves the right to make product and publication changes at any time without notice or obligation.

# SCOOTER SAFETY

## IMPORTANT SAFETY INFORMATION

It will be used with pleasure for a longer time if you take responsibility for your safety and understand the challenges that you could face on the road. There is much that you can do to protect yourself. Here are many helpful recommendations and some very important tips in this manual.

### **Wear a helmet**

The safety equipment starts with a quality helmet. One of the most serious injuries in a crash is a head injury. Always wear a properly approved helmet and also wear suitable eye protection.

### **Make you easy to see**

To make yourself more visible, wear bright reflective clothing to position yourself clearly so that other drivers can see you, signal before making a turn or changing lanes, and use your horn because it will help others notice you.

### **Know your Limits**

Always ride within the limitation of personal skills. Knowing these limits and staying within them will help you to avoid accidents.

## **Keep the vehicle in safe condition**

For safe riding, it's important to inspect the vehicle before every ride and perform all recommended maintenance. Never exceed load limits, and only use the approved accessories.

### **Inspect the vehicle before riding**

Do not forget to perform an entire safety inspection to ensure safety for all riders before riding.

### **Be very conscious on a rainy day**

Riding on a rainy day requires extra caution especially when it's wet. Braking distance is longer on a rainy day. Keep off the painted surfaces, manhole covers and greasy spots on the paved road as it can be especially slippery. Use extreme caution on the railway crossing or on the metal surface. Whenever in doubt about the road condition, please slow down.

### **Modification**

Modification on the vehicle or removal of original equipment may have the vehicle become unsafe or illegal. Obey all the related equipment regulations from the authority.

# SCOOTER SAFETY

## PROTECTIVE CLOTHING

For your safety, always wear an approved scooter or scooter helmet, eyes protection, boots, gloves, long pants, and a long-sleeve shirt or jacket during a ride.

## Helmets and protection

The helmet is the most important gear because it offers the best protection against head injury. The helmet should fit your head comfortably and securely. Always wear a face shield or goggles to protect eyes, but not to interfere with the vision.

## Additional riding gears

In addition to the head and eyes protection, you should also use:

Sturdy boots with non-slip soles to help protect feet and ankles.

Leather gloves to keep your hands warm and prevent blisters, cuts, burns and bruises.

A scooter suit is designed for comfort as well as protection. Bright color with reflection strips can make you more noticeable. Be sure to avoid loose clothes that could get caught on any part of the vehicle.

The recommended riding gears:

- ①Wear gloves
- ②Clothes that fit properly
- ③Always wear a helmet with eye protection
- ④Wear bright or reflective clothing
- ⑤Footwear should be the proper size, have low heels, and offer ankle protection.



## WARNING

- Not wearing a helmet increases your chance of serious injury or death in an accident.
- Be sure your passenger and you always wear an approved scooter helmet that fits properly. You should also wear eye protection and other protective clothing during a ride.



## ACCESSORIES & MODIFICATION

There is a large variety of accessories available to KYMCO vehicle owners. KYMCO cannot have direct control over the quality or suitability of accessories you may wish to purchase. The addition of unsuitable accessories can lead to unsafe operation. It is not possible for KYMCO to test each accessory on the market or combinations of all the available accessories; however, the KYMCO dealer can assist you in selecting quality accessories and then install them correctly.

**Use extreme caution when selecting and installing the accessories.**

### **No modifications:**

KYMCO strongly advises against removing any original equipment or modifying the vehicle in any way that will change its design or operation.



## **WARNING**

Improper accessories or modifications can make the vehicle unsafe and can lead to an accident.

Never modify the vehicle through the improper installation or use of accessories. All parts and accessories added to this vehicle should be genuine KYMCO parts or equivalent components designed for use on this vehicle and should be installed and used according to the correct instruction. If you have any questions, consult the authorized KYMCO dealer.

# LOCATION OF PARTS & CONTROLS

- ① Rear Brake Lever
- ② Headlight
- ③ Front Left Turn Signal Light
- ④ Reflector
- ⑤ Helmet Hook
- ⑥ Side Stand
- ⑦ Engine Number
- ⑧ Air Cleaner
- ⑨ Tail/Brake Light
- ⑩ Rear Left Turn Signal Light
- ⑪ Fuel Filler Cap
- ⑫ Luggage Box
- ⑬ Seat

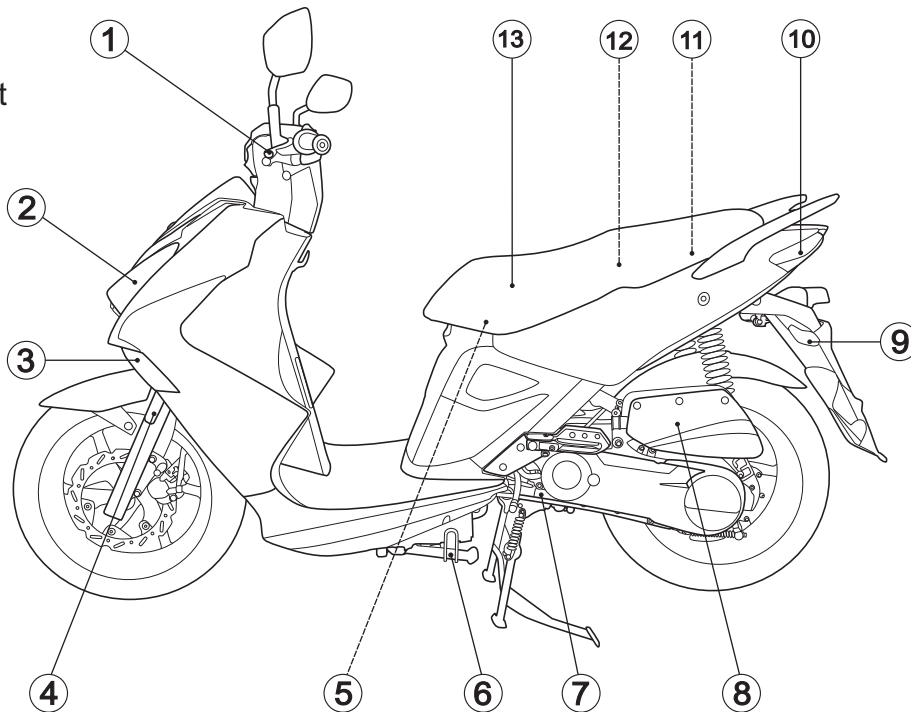

■ **NOTE:** Your scooter may differ slightly in appearance from the images in this manual.

# LOCATION OF PARTS & CONTROLS

- ⑭ Right Turn Signal Light
- ⑮ Muffler
- ⑯ Oil Filler Cap/dipstick
- ⑰ Center Stand
- ⑱ Rear Passenger Foot Peg
- ⑲ Vehicle Identification Number
- ⑳ Right Turn Signal Light
- ㉑ Front Brake Lever
- ㉒ Electric Starter Button
- ㉓ Ignition Switch

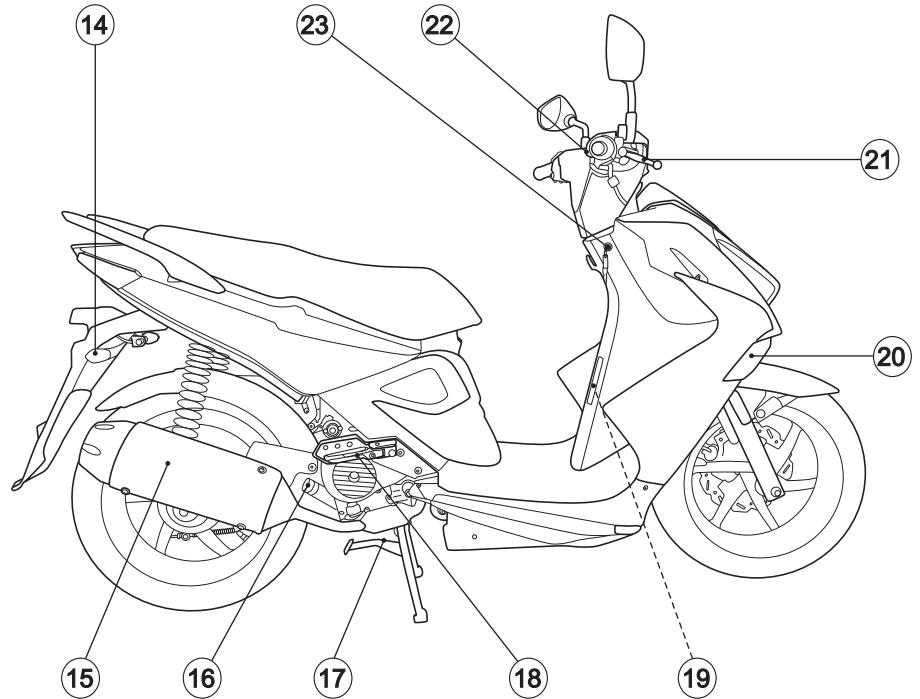

■ **NOTE:** Your scooter may differ slightly in appearance from the images in this manual.

# LOCATION OF PARTS & CONTROLS

- ②④ Right Rearview mirror
- ②⑤ Left Rearview mirror
- ②⑥ Right Turn Signal Light
- ②⑦ Left Turn Signal Light

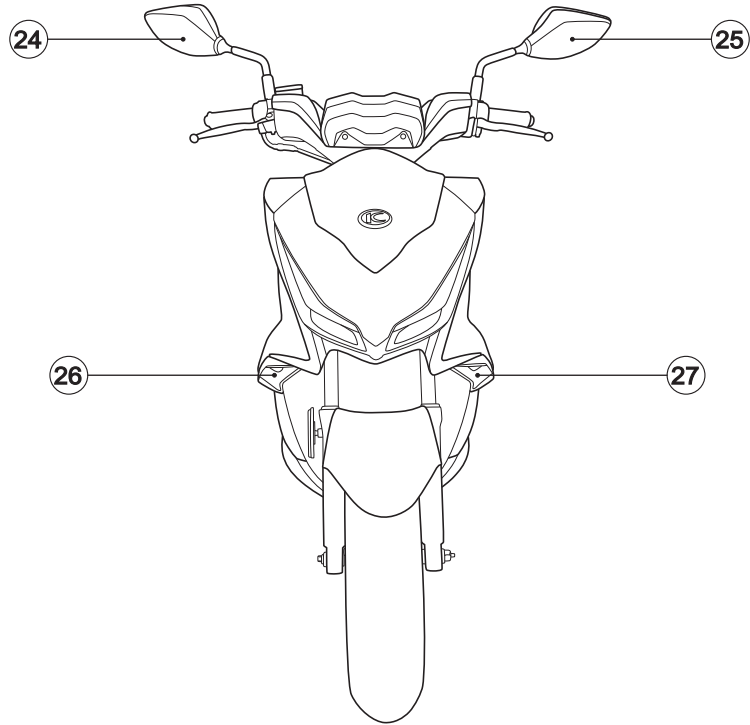

■ **NOTE:** Your scooter may differ slightly in appearance from the images in this manual.

## SECTION 2 - CONTROLS & FEATURES

### IGNITION SWITCH

Use the ignition key to operate the ignition switch, the steering lock and open the seat.

#### ① “ ON ” Position:

The ignition circuit is "ON" and engine can now be started. The key can not be removed from the ignition switch in this position.

#### ② “ OFF ” Position:

All electrical circuits are off. The engine can't run or be started.

#### ③ “ LOCK ” Position:

To lock the steering, turn the handlebar all the way to the left, push down and turn the key to the "LOCK" position and remove the key. All electrical circuits are off.

### ⚠ CAUTION

After locking the ignition switch, turn the handlebar gently to confirm that the steering is locked.

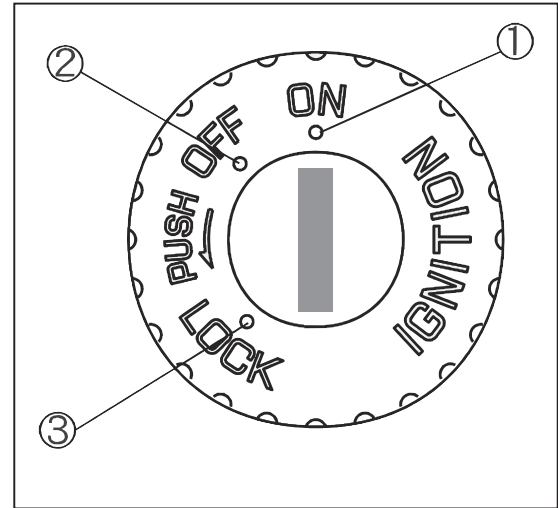

### WARNING

Do not turn the ignition switch to the lock position when riding, as this could cause the steering to lock and result in you losing control of your scooter. Do not park your scooter in a position that will interfere with vehicle or pedestrian traffic.

# CONTROLS & FEATURES

## INSTRUMENTS

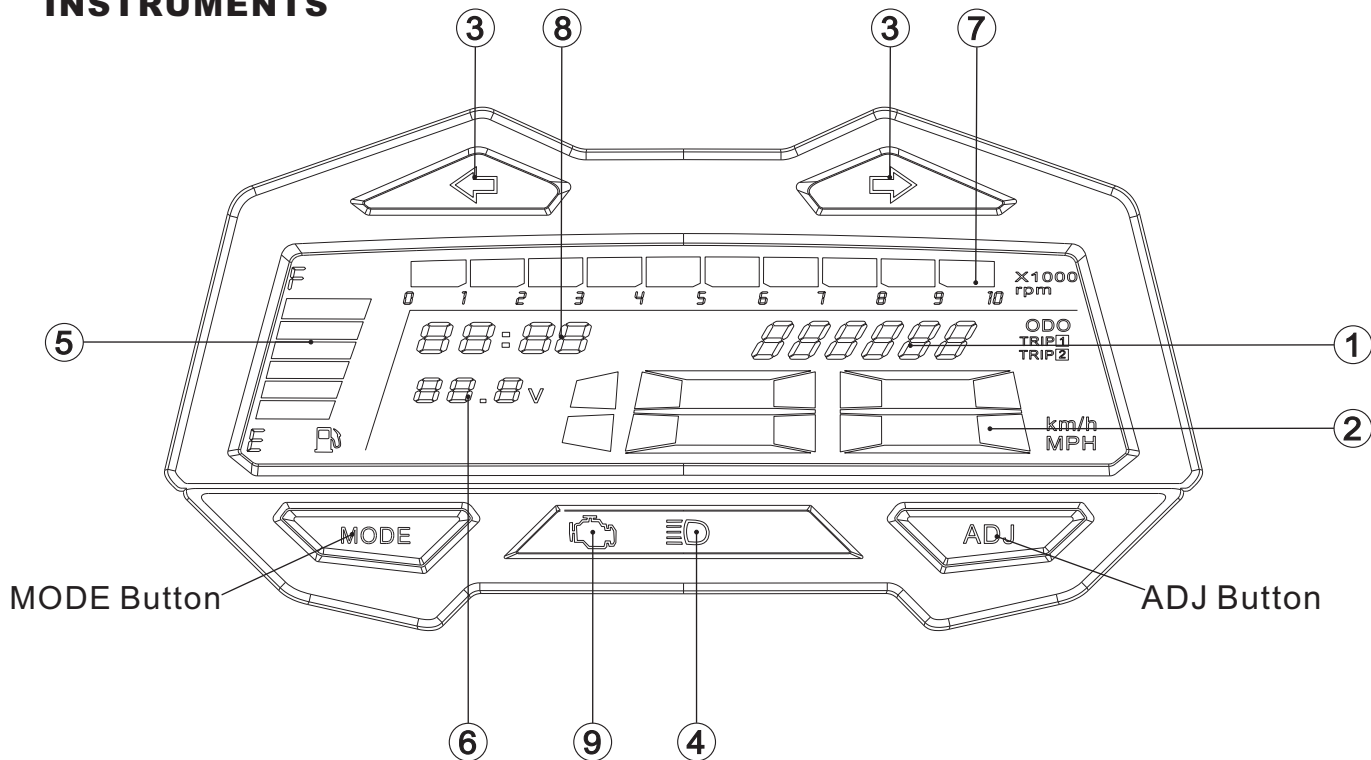

# CONTROLS & FEATURES

## ① Odometer/Trip meter:

- Press MODE button to toggle between ODO mode, Trip1/2 mode and oil service mode(blank mode).
- Choose Trip or oil service mode, hold both MODE and ADJ for 2 seconds to reset.
- Press the ADJ to toggle between km and mile.

## ② Speedometer: Indicates the road speed in km/h or MPH

## ③ Turn Signal Indicator Light: Flashes when either turn signal is being used.

## ④ High Beam Indicator Light: This light is illuminated when the high beam is on.

## ⑤ Fuel Level Meter: It displays how much fuel left in the fuel tank. When the needle approaches "E" this indicates the tank is near empty and should be refilled with unleaded gasoline.

## ⑥ Battery voltage display

## ⑦ Tachometer:

Indicates the engine speed in the revolutions per minute (RPM).

## ⑧ Digital Clock

## ⑨ CELP indicator:

If it keeps on after starting the engine, it indicates that a fault has been detected in the EFI or electrical system. It needs immediate inspection by the authorized KYMCO dealer.

■ **NOTE:** CELP lights on when you turn on the ignition switch, it goes off after start the engine.

# CONTROLS & FEATURES

## Service display Reset:

After you change the engine oil, you need to reset the Service display.

1. Press MODE button to toggle between ODO mode, TRIP1/2 mode and oil service mode(blank mode).
2. Choose oil service mode(blank mode). press MODE button and ADJ button at the same time for 2 seconds and the display will turns to 0.0, the service display is reset.
3. The service display will flash again when you reach next 2000KM

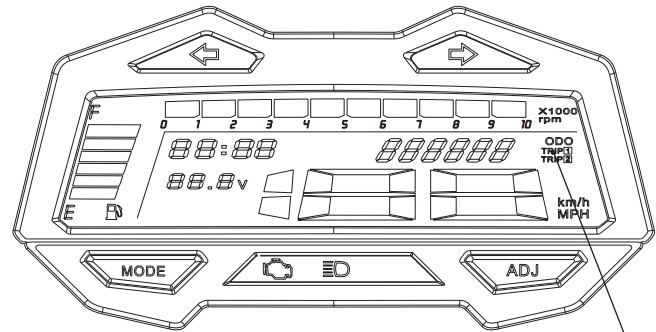

Service display

■ **NOTE:** When the service display is on, the ODO/TRIP1/2 service will flash.



# CONTROLS & FEATURES

## Adjust clock

### The setting procedure:

1. Turn the ignition switch to the ON position.

2. Push the MODE button to toggle between ODO mode, TRIP1/2 mode, oil service (blank mode).

■ **NOTE:** The digital clock can be only adjusted in ODO mode.

3. Push both MODE and ADJ for more than 2 seconds. The “hour” digits will begin flashing, you can adjust it by pressing ADJ button.

4. Push the MODE button, the minute digits will begin flashing, you can adjust it by pressing ADJ button.

5. Push both the MODE and ADJ at the same time to finish the clock setting.

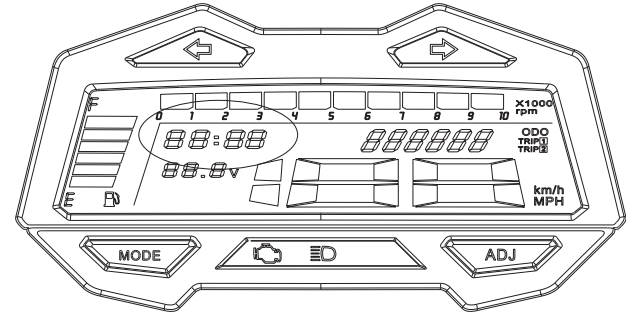

■ **NOTE:** The adjustment will be cancelled if any button is not pressed within approximate ten seconds.

■ **NOTE:** The clock will be reset to 12:00 when the battery is disconnected.

# CONTROLS & FEATURES

## Passenger foot pegs

Your scooter is equipped with additional pegs for use when you are carrying a passenger.

1. To move the passenger pegs from the scooter's body, press the release button ①.
2. When you are not carrying a passenger, press the pegs back into place.



## WARNING

- Riding with a passenger will change the handling characteristics of your scooter. Allow for extra braking distance and use extra care when riding in traffic.
- Be sure you and your passenger always wear an approved motorcycle helmet that fits properly. You should also wear eye protection and other protective apparel when you ride.

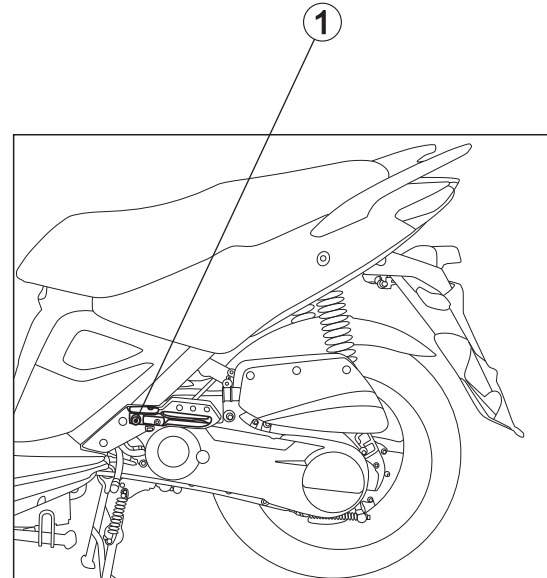

# CONTROLS & FEATURES

## Right handlebar switch

### Starter button ①:

Press starter button “” and pull brake lever in the meantime to actuate the starter motor.

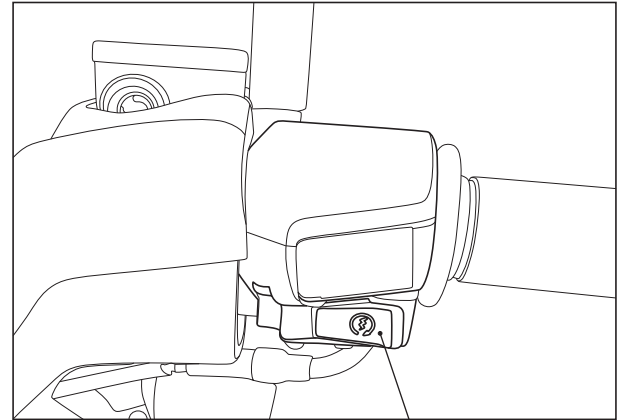

①

■ **NOTE:** Hold the brake lever, or the starter motor won't work. Don't press the starter button while the engine is running.

# CONTROLS & FEATURES

## Left handlebar switch

### Turn signal switch ① :

Push to signal other drivers for an intention to make a turn or change a lane. The turn signal light is blinking while the switch is pushed left or right.

" ← " for left turn.

" → " for right turn.

To stop the turn signal, push the switch again.

### Horn button ② :

Press the horn button to sound the horn.

### Dimmer switch ③ :

Switch to select the light with high or low beam.

" ≡ D " for low beam.

" ≡ D " for high beam.

### Passing button ④ :

Press this button to flash the headlight with high beam to signal other drivers ahead for an intention to overtake.

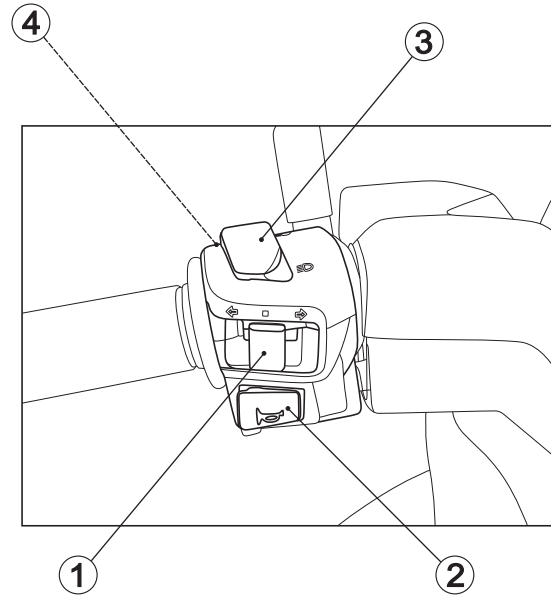

# CONTROLS & FEATURES

## Fuel level inspection / Refilling

When the fuel level gauge approaches "E" (indicating the tank is nearly empty), quickly refill the fuel tank with the specified unleaded gasoline.

## Fuel tank filler:

### To refuel, do the following :

1. Use the ignition key to unlock the seat.
2. Turn the fuel filler cap counter-clockwise.
3. Once unlocked, it's able to take the fuel cap away.

### To install the fuel cap, do the following:

1. Press it back into place on the fuel filler neck.
2. Turn the fuel filler cap clockwise.
3. To lock the seat .

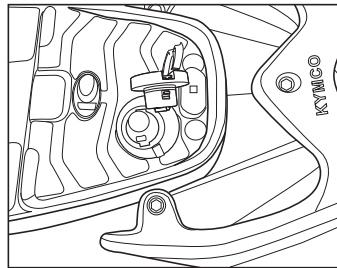
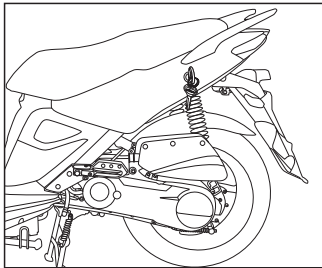

## Fuel Type and Octane Rating

Use clean, fresh unleaded gasoline with an ethanol volume content not more than 5% and an octane rating equal to or higher than that shown in the table.

Fuel Type	Unleaded Gasoline
Ethanol Content	E5 or less
Minimum Octane Rating	Research Octane Number (RON) 92

■ **NOTE:** Gasoline containing up to 5% ethanol by volume

## Fuel recommendation

In order to prevent fire risks caused by fuel overflow from the Fuel Inlet, make sure the Fuel Tank Cap is fully locked after refueling.

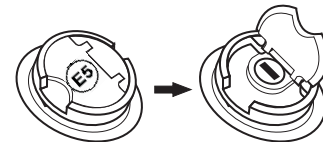

# CONTROLS & FEATURES

## Seat

### To unlock the seat

Insert and rotate the key clockwise in the seat lock. When the Seat latch releases, lift up the seat.

### To lock the seat

lower the seat and press down until it is secured by the latch. Gently lift up on the back edge of the lid to make sure it is locked in place before riding.

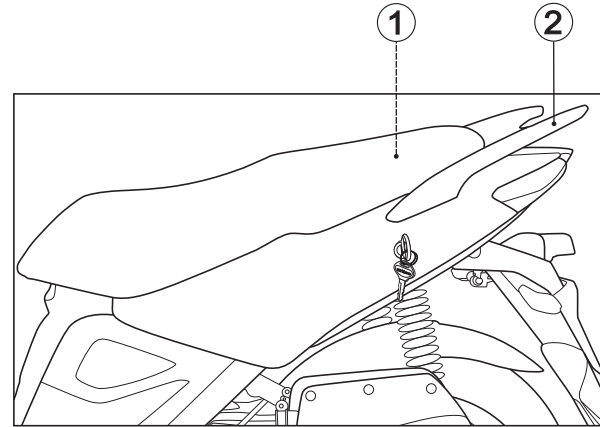

## WARNING

Never exceed the maximum weight limit of the storage compartment, as the handling and stability of your scooter may be affected. Do not leave the ignition key under the seat.

### Maximum cargo weight:

- ① LUGGAGE BOX.....10KG
- ② REAR CARRIER .....5KG

# CONTROLS & FEATURES

## Helmet Holder

To use the helmet holders, open the seat and hang the helmet on the holder hook (1), then lock the seat securely.

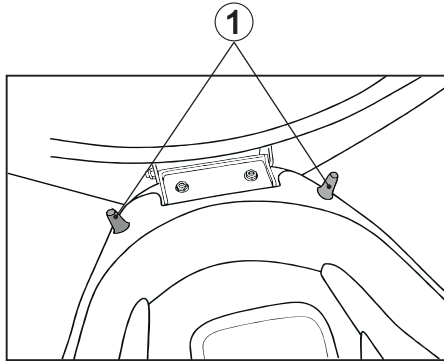

## HOOK

If you need to use the front hook, press button (2) the hidden hook will come out.

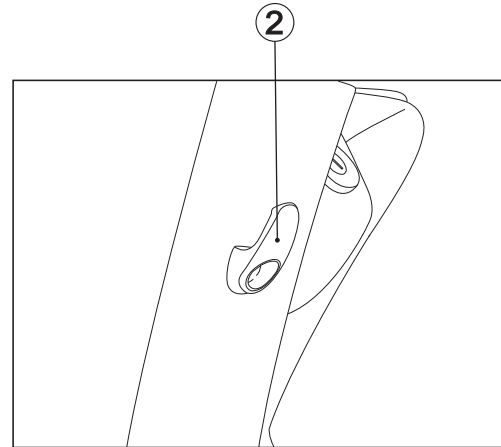

## WARNING

Use the helmet holder only on parking.  
Do not ride with a helmet hanged on the holder.

## Maximum cargo weight:

HOOK FRONT.....3KG

# CONTROLS & FEATURES

## Suspension

Each shock absorber assembly is equipped with a spring preload adjusting ring.

Adjust the spring preload as follows.

To increase the spring preload and thereby harden the suspension, turn the adjusting ring on each shock absorber assembly in direction (a). To decrease the spring preload and thereby soften the suspension, turn the adjusting ring on each shock absorber assembly in direction (b).

Align the appropriate notch in the adjusting ring with the position indicator on the shock absorber.

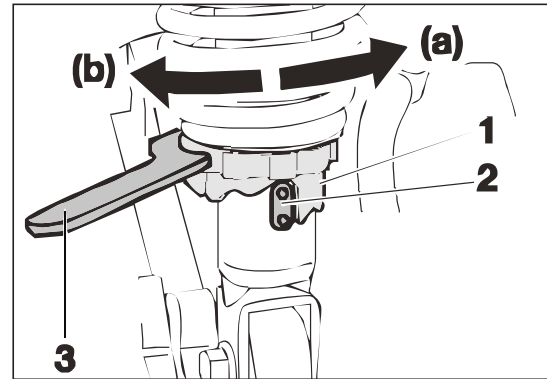

## WARNING

Be certain to adjust both shock absorber to the same spring preload position.

Improper setting of shock absorber will cause unstable handling and might lead to an accident.

1. Spring preload adjusting ring
2. Position indicator
3. Spring preload adjusting tool



## SECTION 3- OPERATION

### Pre-ride inspection

For your safety, it is very important to spend a few moments before each ride to walk around the motorcycle and check its condition. If you detect any problem, be sure to deal with it, or have the KYMCO dealer to fix it.



### WARNING

Improper maintenance of the motorcycle or failure to solve a problem before riding can cause a crash in which you can be seriously hurt or killed. Always perform a pre-ride inspection before every ride and solve any problems.

#### 1. Engine oil level:

Add engine oil if required.  
Check if there's a kind of leakage.

#### 2. Fuel level:

Fill fuel tank when necessary. Check if there's a kind of leakage.

#### 3. Front and rear brakes:

Check operation and make sure there is no brake fluid leakage.

#### 4. Tires:

Check condition and inflation pressure.

#### 5. Throttle:

Check for smooth operation and that it can be closed completely in all steering positions.

#### 6. Lights and horn:

Check that headlight, tail/brake light, turn signals, indicators and horn function properly.

#### 7. Steering:

Check for condition and smoothness.

# OPERATION

## **Break-in**

The first 1600km (1000 miles) of riding is very important to the life of usage. Proper break-in operation during this period will help ensure maximum life and performance. The reliability and performance depend on a special care and limited operation during the break-in period.

The following limitations should be complied during the break-in period:

### **Initial 800km (500 miles):**

Less than 1/2 throttle or not over

### **Up to 1600km (1000 miles):**

Less than 3/4 throttle

## **Vary the engine speed**

The engine speed should be varied and not held constantly for a long time and also prohibited to have heavy load during the break-in period.

## **Avoid constant low speed**

Operate the engine at constant low speed even of light load may cause the running part a fit-in problem. Be sure to start up the engine gently during the break-in period.

## **Avoid full throttle operation**

Operate the engine at high speed may cause running part a lubrication problem. Be sure to keep in the limited speed range during the break-in period.



## **WARNING**

The 1000km (600 miles) initial service is very important to ensure an optimum vehicle condition in the future.

# OPERATION

## Starting the engine

Always follow the proper starting procedure described here and on the following pages.

### CAUTION

To protect the catalytic converter in the engine's exhaust muffler, avoid idling too long and do not use leaded gasoline.

### CAUTION

To prevent damage to the starter motor, do not operate the starter motor for more than 5 seconds at a time. If you fail to start successfully, check the fuel level and the battery condition, and waiting for 15 seconds between each fail to start.

1. Position the scooter by the center stand and put the side stand up.
2. Insert the ignition key and turn it to “ ON ”

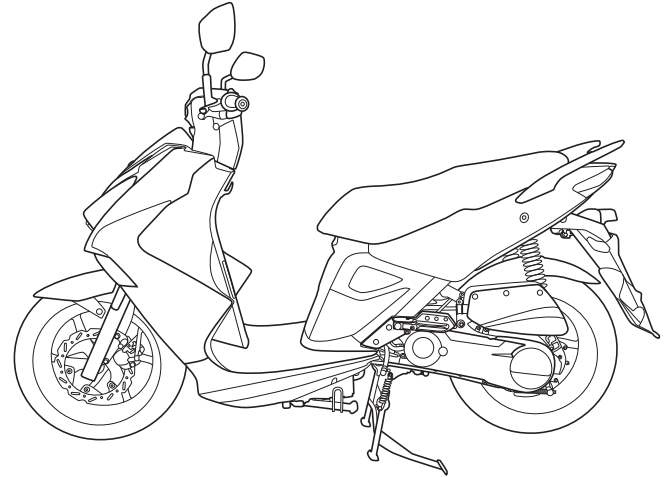
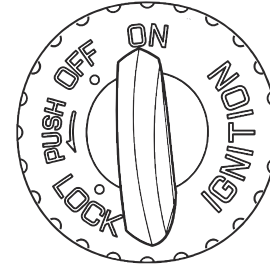

# OPERATION

3. Squeeze the left (rear) brake lever to connect electric power for ready to start engine .
4. Press the starter button ① with the throttle closed, releases it at once as the engine starts.
5. Keep the throttle closed while warming up the engine.
- 6.Keep the engine warming up thoroughly before each ride.

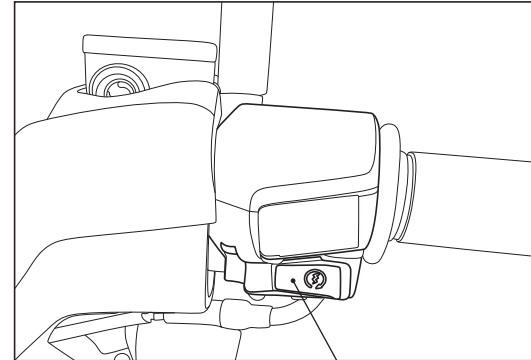
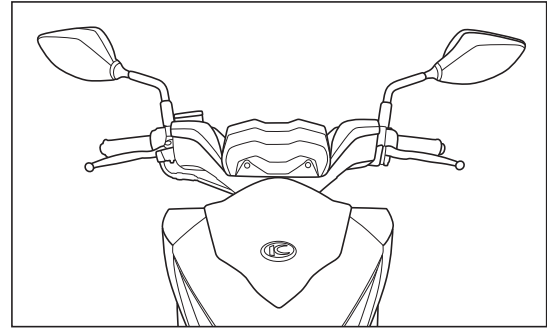

## CAUTION

After starting, allow the engine oil to circulate before riding your scooter. Allow sufficient idling time after warm or cold engine start-up before applying load or reviving the engine. This allows time for the lubricating oil to reach all the critical engine components.

## SECTION 4 - MAINTENANCE

### The importance of maintenance

Maintaining the scooter properly is essential for safe, economical and trouble-free riding. It will also help reduce air pollution and maximize fuel economy.

To properly take care of the scooter, the following pages in this Owner's Manual include a maintenance schedule to help you make sure the scooter is serviced at the appropriate intervals.

These instructions are based on the assumption that the scooter will be used normally on the design purpose. Usually under high speed driving or riding in unusually wet or dusty area will require more frequent service than specified in the maintenance schedule. Consult with the KYMCO dealer for recommendations about your personal needs.

■ **NOTE:** Always follow the inspections, service recommendations and schedules on later pages.



### WARNING

If the scooter turnovers or becomes involved in a crash, be sure to have the KYMCO dealer inspect all major parts, even if you are able to make some repairs. Improper maintenance of the scooter or failure to solve a problem before next riding could result in a crash in which you could be seriously hurt or dead.



### WARNING

When performing maintenance service on the scooter you may need to start the engine. Running the engine indoors can be hazardous. Exhaust gas contains carbon monoxide which is colorless and odorless, and can cause death or severe injury. Start the engine only where is ventilated well, preferably operate outdoors.

# MAINTENANCE

## Maintenance schedule

Perform the pre-ride inspection at each scheduled maintenance period. This interval should be judged by odometer reading or by months, whichever comes first.

## Maintenance schedule chart:

**I:** INSPECT AND CLEAN, ADJUST, LUBRICATE OR REPLACE IF NECESSARY

**C:** CLEAN **R:** REPLACE **A:** ADJUST **L:** LUBRICATE **D:** DIAGNOSE **T:** TIGHTENING

The maintenance schedule on the following two pages specifies the maintenance required to keep the scooter in good running condition. Maintenance should be performed according to the design standards and specifications by the authorized KYMCO dealer.

- \* Be serviced by the KYMCO dealer, unless you have the proper tools, service data and are technically qualified.
- \*\* For safety reason, we recommend these items be serviced only by the KYMCO dealer. KYMCO recommends that the KYMCO dealer should take a road test after each maintenance service.

## NOTES:

1. For higher odometer readings, repeat by the service interval illustrated here.
2. Service more frequently for long-term riding in unusually wet or dusty areas.
3. Service more frequently for long-term riding in rain or with full throttle.
4. Inspect every 5000 km (3000 mi) after replacement and replace every 10000 km (6000 mi).
5. Replace every 5000km (3000mi) or every 6 months. Replacement requires mechanical skill.
6. Replace every 2 years. Replacement requires mechanical skill.
7. Replace every 2000km(1200mi), Inspect every 1000km(600mi) ,Add engine oil if required.

# MAINTENANCE

FREQUENCY		WHICHEVER COMES FIRST	ODOMETER READING [NOTE (1)]								REFER TO PAGE	
			X 1000 km	0.3	1	3	5	7	9	11		
ITEM		NOTE	MONTH	X 1000 mi	0.2	0.6	1.8	3	4.2	5.4	6.6	
						3	6	12	18	24	30	
*	AIR CLEANER	NOTE 2			I	R	I	R	I	R		39
	SPARK PLUGS	NOTE 4					R		R			41
*	THROTTLE OPERATION						I		I			40
*	VALVE CLEARANCE				A		A		A			-
*	FUEL LINE						I		I			-
	CRANKCASE BREATHER	NOTE 3			C	C	C	C	C	C		-
	ENGINE OIL	NOTE 7		R	R	R	R	R	R	R		36
*	ENGINE OIL SCREEN			C	C	C		C		C		-
*	ENGINE IDLE SPEED						I		I			-
	TRANSMISSION OIL	NOTE 5		R		R		R		R		38
*	DRIVE BELT			Inspect every 5000km,replace every 20000km								-

# MAINTENANCE

FREQUENCY		WHICHEVER COMES FIRST	ODOMETER READING [NOTE (1)]							REFER TO PAGE		
			X 1000 km	0.3	1	3	5	7	9		11	
ITEM		NOTE	MONTH	X 1000 mi	0.2	0.6	1.8	3	4.2	5.4	6.6	
					3	6	12	18	24	30		
* *	CLUTCH SHOE WEAR											-
	BRAKE FLUID	NOTE 6		Replace at every 10000km, or every year							42	
	BRAKE PAD WEAR											-
	BRAKE SYSTEM											-
*	BRAKE LIGHT SWITCH											-
* *	STEERING BEARINGS											-
*	HEADLIGHT AIM											-
*	NUTS, BOLTS, FASTENERS				T	T	T	T	T	T		-
* *	WHEELS/TIRES											48
*	CVT FILTER							C		C		
*	INJECTOR				D	D	D	D	C	D		



# MAINTENANCE

## Engine oil

### Engine oil recommendation

Use a high quality 4-stroke engine oil to ensure a longer life. Choose SL oil or higher according to the classification of API.

### Engine oil viscosity : SAE 15W-40

If these viscosities are not available, select an alternative engine oil according to the chart shown below.

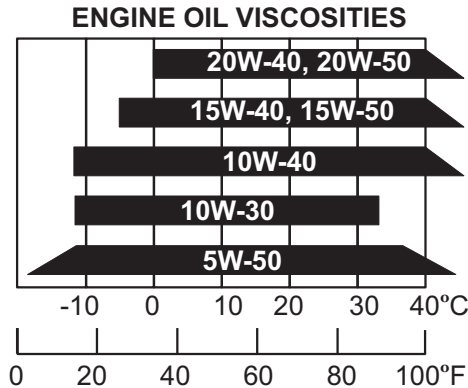

**Full capacity:** 0.85L(0.80 US qt)

**Exchange capacity:** 0.7L(0.66 US qt)

## Engine oil level inspection

Check the engine oil level each day before riding your scooter. The level must be maintained between the upper ① and lower level ② marks on the oil filler cap/dipstick ③.

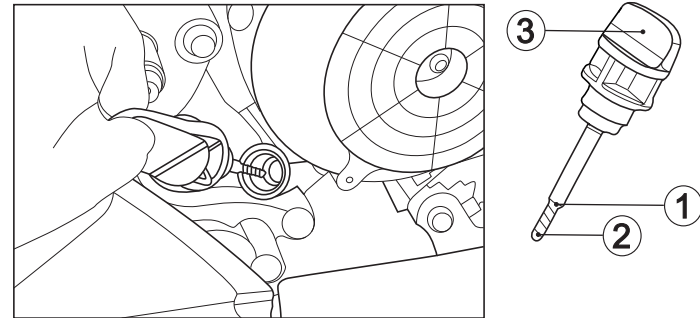

### ⚠ CAUTION

Do not operating the scooter with a low and higher oil level . A low level can cause low oil pressure. Running the engine with insufficient oil pressure can cause serious engine damage. Overfilling the engine can cause oil leaks or oil contamination of the air filter element. Always make sure the oil level is above the "L" mark but not higher than the "F" mark on the dipstick.

# MAINTENANCE

- Start engine and keep idling for a few minutes.
- Stop the engine and stand the scooter on level ground by center stand.
- Wait a while, remove the oil level dipstick.
- Wipe oil off, then reinsert the oil level dipstick without screwing in.
- Remove the oil level dipstick. The oil level should be between the high and low lines on the dipstick.
- If required, add the specified oil so the oil level reaches the high level line on the dipstick.  
Do not overfill.
- Reinstall the oil level dipstick. Check for oil leaks.



## WARNING

The engine and related parts can become very hot. Be careful when inspecting the oil level so not to suffer burns. Make the engine and exhaust system cool down before inspection.

## Engine oil replacement

Engine oil quality is the major factor that affects engine life. Change your scooter's engine oil as specified in the maintenance schedule.

- Warm engine up thoroughly then stop.
- Stand vehicle by using the center stand
- Place an oil container beneath the drain hole.
- Remove the oil level dipstick.
- Remove the drain bolt and drain off thoroughly
- Tighten the drain bolt to the specified torque.
- Add oil to reach the high line on the dipstick
- Screw the oil level dipstick into place securely.

Tightening torque

Engine oil drain bolt: 25N·m (2.5kg·m, 18ft·lb)



## CAUTION

Use the genuine engine oil or another with the same quality and grade to avoid burnout on the engine parts.

# MAINTENANCE

## Transmission Gear Oil change

1. Stand the scooter by the center stand.
2. Remove the gear oil drain bolt ①.
3. Remove the gear oil filler bolt ②, and then slowly rotate the rear wheel to drain the gear oil off.
4. Fill with the recommended oil to reach the capacity listed below.
5. Install the transmission filler bolt and tighten it to the specified torque.

**Gear oil type:** SAE 90

**Full capacity:** 0.20 L (0.19 US QT)

**Exchange capacity:** 0.18L (0.17 US QT)

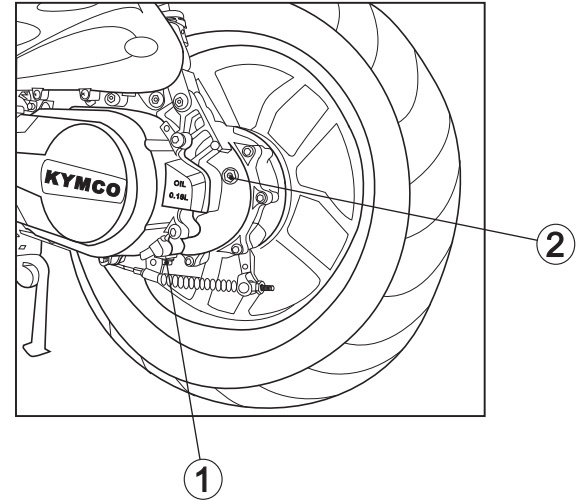

### ⚠ CAUTION

Use the genuine engine oil or another with the same quality and grade to avoid burnout on the bearing or damage on the gear set.

### ⚠ CAUTION

Must follow the local regulation and obey the related prohibition about the disposal of oil.

# MAINTENANCE

## Air cleaner filter element

The air cleaner filter element should be serviced at regular intervals by the KYMCO dealer.

### Removal of the air cleaner filter

1. Remove the screws ① from the air cleaner cover and remove the air cleaner cover.
2. Remove the bolts from air cleaner filter ②, replace it with a new one

■ **NOTE:** Have the element serviced more often when riding in unusually wet or dusty areas.

## ⚠ CAUTION

- Improper installation for the filter can cause water or dirt to enter the engine causing premature wear. Using the wrong KYMCO air cleaner element or a non-KYMCO air cleaner element which is not of equivalent quality may cause premature engine wear or performance problems.
- Air cleaner is an important part of your scooter, please go to a KYMCO dealer for air cleaner service.

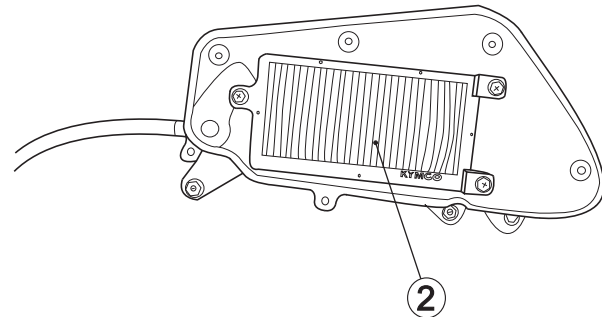
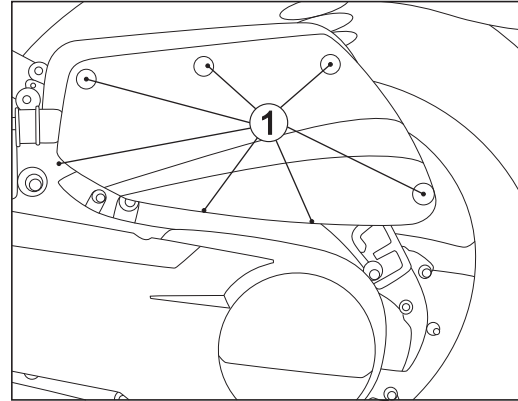

# MAINTENANCE

## Throttle operation

The throttle operation and free play must be inspected and adjusted periodically (as part of the pre-ride inspection).

1. Before riding, check for smooth rotation from fully open to fully closed at both full end of steering.
2. Measure the throttle free play as shown at right.

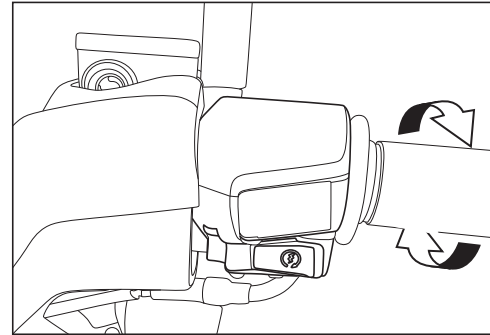

**Throttle free play:** 2.0 - 6.0 mm (0.08-0.24 in)

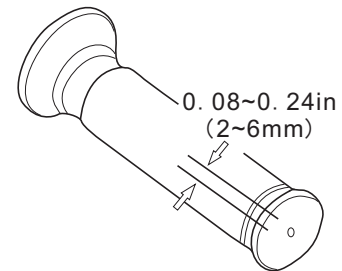

■ **NOTE:** If your scooter's throttle free play requires adjustment, contact your KYMCO dealer for service.

# MAINTENANCE

## Spark plug

Remove the carbon deposits from the spark plug with a nonmetal brush and the suitable solvent. After cleaning, check to adjust the spark plug gap to specified limit by using a spark plug gap thickness gauge. The spark plug should be replaced periodically.

Recommend to consult with the KYMCO dealer when choosing an alternative spark plug instead.

**Recommended spark plug** : CR7HSA(NGK)

### ⚠ CAUTION

An improper spark plug may have an incorrect fit or heat range for your engine. This may cause severe engine damage which will not be covered under warranty. Never use a spark plug with an improper heat range, as it can result in severe engine damage.

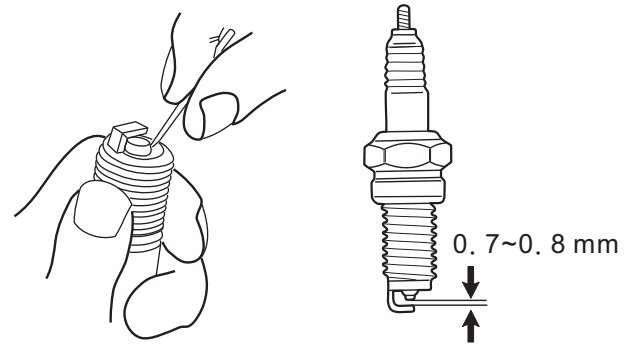

**Spark plug gap: 0.7~0.8 mm**

# MAINTENANCE

## Brake fluid

### Brake fluid level inspection

With the scooter in an upright position, check the front and rear fluid level. Change the brake fluid at the time specified in the maintenance schedule.

The fluid level should be above the lower level line ①. If the fluid level is below the lower level mark "L", check over the worn brake pad or leakage.

■ **NOTE:** Make sure there is no fluid leaking. Check for fluid deterioration or crack on the brake hoses and fittings.

**Brake fluid type:** DOT- 4

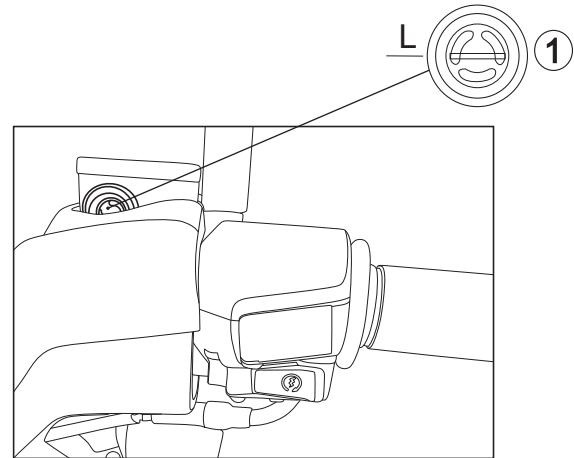

## WARNING

Use only DOT-4 brake fluid from a sealed container. Clean the filler cap before removing.

# MAINTENANCE

## Brake Pad Inspection

Inspect the thickness of brake pad to verify if there is enough lining to brake properly.

If the wear indicated groove at the brake pad is no longer visible, this means that the brake pad is worn and requires replacement.

Before riding, apply braking several times to reach the proper lever stroke and firm feel on braking action that will ensure the brake pads are pressed against the brake disks securely.



## WARNING

The brakes will wear quickly if the lever is continually applied during riding.

The worn brake pad will increase the stop distance and may cause an accident easily.

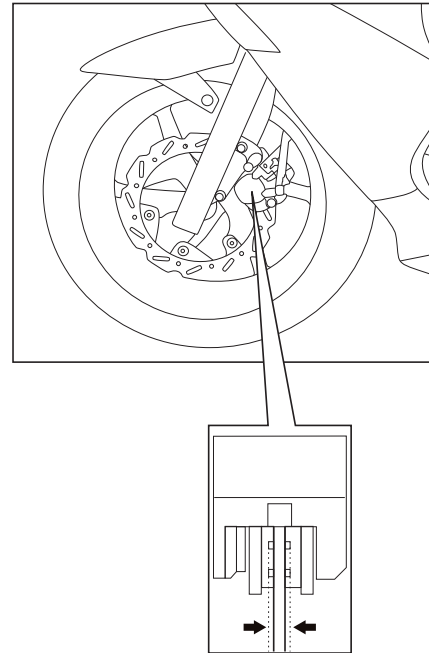



# MAINTENANCE

## Brake lever free play inspection & adjustment

Before riding, inspect the rear brake lever free play and adjust it to the specified amount. Measure the gap to within 1-2cm of the specified range.

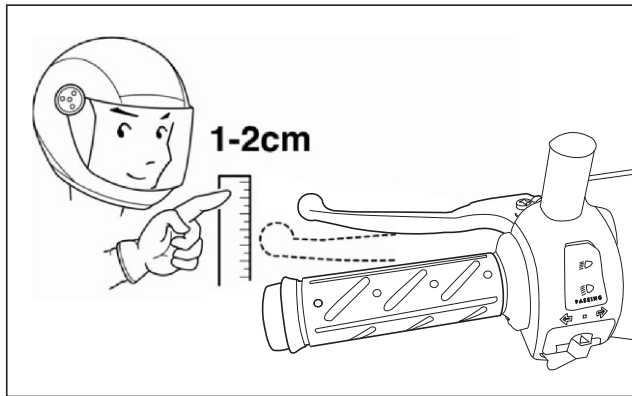

Rotate the adjuster nut ① clockwise to reduce the brake lever free play. Rotate the adjuster nut counterclockwise to increase the brake lever play.

## Brake pad inspection

Inspect the brake pad and shoe thickness to verify there is enough material for the brakes to function properly. If the "Δ" mark on the rear brake indicator ② aligns with the "Δ" mark on the brake hub, it is an indication that the brake shoes are worn and require replacement.

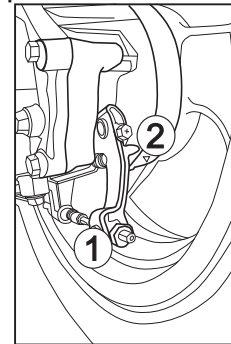

Adjustment nut

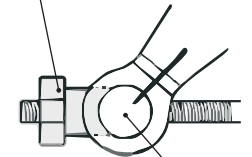

Pin



## WARNING

For appropriate brake action, make sure the groove of the adjusting nut is aligned with the pin in the brake arm.

# MAINTENANCE

## Battery

The battery is a sealed type, so it is unnecessary to check the battery's electrolyte level or add distilled water any more.

■ **NOTE:** If your battery seems weak or the electrolyte is leaking to cause hard start or other electrical troubles, contact the KYMCO dealer immediately.

- Disconnect the negative (-) terminal ①.
- Disconnect the positive (+) terminal ②.
- Remove the disabled battery.
- To reinstall is the reverse sequence of removal.

■ **NOTE:** If the cap strip is removed, the battery will become permanently damaged.

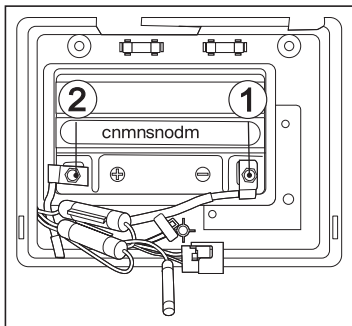

## WARNING

Electrolyte is toxic and dangerous since it contains sulfuric acid, which causes severe burns. Avoid any contact with skin, eyes or clothing and always shield your eyes when working near batteries. In case of contact, administer the following FIRST AID.

External: Flush with plenty of water.

Internal: Drink large quantities of water or milk and immediately call a physician.

Eyes: Flush with water for 15 minutes and seek prompt medical attention.

Batteries produce explosive hydrogen gas. Therefore, keep sparks, flames, cigarettes, etc., away from the battery and provide sufficient ventilation when charging it in an enclosed space.

**KEEP THIS AND ALL BATTERIES OUT OF THE REACH OF CHILDREN.**

# MAINTENANCE

## Fuse

When fuse fails frequently, it usually indicates a short circuit or an overload in the electrical system.



## WARNING

- Never use a fuse of different rating.
- If the new fuse blows in a short time, consult the KYMCO dealer immediately.

## Fuse Allocation

All functional fuses are located in the fuse box, there's a sticker on the back of the fuse box cover. Fuse should be inserted according to this sticker.

## Fuse Specifications

10A\*1 15A\*1 7A\*1

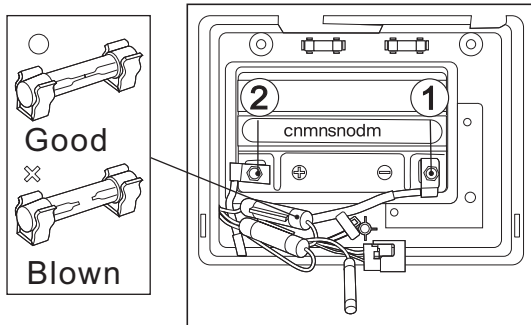

# MAINTENANCE

## Tires

### Tire pressure

Insufficient tire pressure not only advances wear but also affects the riding stability. Under-inflated tires make turning not smooth and over-inflated tires decrease the contact area with the ground, which can lead to skid and loss of control. Make sure that the inflation pressure is within the specified limits all the time.

■ **NOTE:** Check the tire inflation pressure and tire tread condition at the interval listed in the periodic maintenance schedule. For maximum safety and better tire life, the tire pressure should be inspected more often.

■ **NOTE:** Tire pressure should only be adjusted when the tires are cold.

Front tire (rider only): 1.50 kg/cm<sup>2</sup>

Rear tire (rider only): 2.00 kg/cm<sup>2</sup>

Front tire (rider & passenger): 1.75 kg/cm<sup>2</sup>

Rear tire (rider & passenger): 2.25 kg/cm<sup>2</sup>



## WARNING

Fail to follow the instruction below may result in an accident due to tire failure. The rider's personal safety is dependent on the condition of the scooter's tires.

Check tire condition and pressure, and adjust the inflation pressure before each ride. Avoid overload on the vehicle.

Replace tires which have been worn to the specified limit, or have any damages such as cuts or cracks.

Always use the designated size and type of tires as specified in this Manual.

Balance the wheel after tire installation.

Failure to perform the break-in of the tires can cause tire slip and loss of control.

Be very careful when riding on new tires as the grip is limited between the ground.

Perform proper break-in of the tires to avoid excessive acceleration, sharp cornering, or hard braking for the first 160 km (100 miles).

# MAINTENANCE

## Tires Inspection

Tire wear changes the tire profile and may affect the vehicle's handling characteristics. Check the tire condition before each riding. Replace the tires if tread depth is less than the following limit:

**Tire tread wear limit: FRONT 1.6 mm  
REAR 2.0 mm**

## Tire size:

Front tire: 120/70-14 TUBELESS  
Rear tire: 120/80-14 TUBELESS

■ **NOTE:** Measure the tread depth ①, do not judge by a visual inspection.

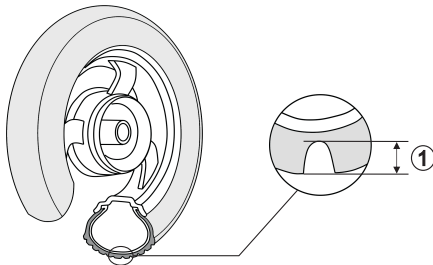

■ **NOTE:** Be sure to balance the wheel after repairing a puncture or the tire. Proper wheel balance is important to avoid variable contact between tire and ground, and to avoid uneven tire wear.

■ **NOTE:** Replace the tires if there's visual evidence of damage as cracks or cuts.



## WARNING

An improperly repaired, installed, or balanced tire can cause you to lose control of your scooter or shorten tire life. Ask the authorized KYMCO dealer, or a qualified tire shop to perform tire repair, replacement, and balancing due to the proper tools and experience are required. Always install tires according to the rotation direction shown by arrow on the sidewall of each tire.

# MAINTENANCE

## Cleaning

Clean your scooter regularly to protect the surface finishes and inspect for damage, wear, and oil, coolant or brake fluid leakage.

Avoid cleaning products that are not specifically designed for scooter, scooter, or automobile surfaces. Nonspecific cleaners may contain harsh detergents or chemical solvents that can damage the metal, paint, and plastic on your scooter.

■ **NOTE:** If your scooter is still warm from recent operation, give the engine and exhaust system time to cool off before washing. Avoid the use of high pressure water spray (typical in coin-operated car washes), as the powerful spray can damage components on your scooter.

## Washing your scooter

1. Rinse the scooter thoroughly with cool water to remove any loose dirt.
2. Clean the scooter with a sponge or soft cloth using cool water. Avoid directing water at muffler outlets and electrical parts.
3. Clean the plastic parts using a cloth or sponge dampened with a solution of mild detergent and water. Rub the soiled area gently, rinsing it frequently with fresh water. Take care to keep brake fluid or other chemical solvents away from the scooter, as they will damage the plastic and painted surface.
4. After cleaning, rinse the scooter thoroughly with plenty of clean water. This rinsing is required to remove detergent residue which can corrode alloy parts.

# MAINTENANCE

## Crankcase Blow-by Drain

The air cleaner has a drain tube ① that is for draining the oil condensed fluid from the crankcase.

When the fluid has accumulated to a certain amount in the transparent drain tube, remove the clip ②, drain the fluid into a container, and then reinstall in place.

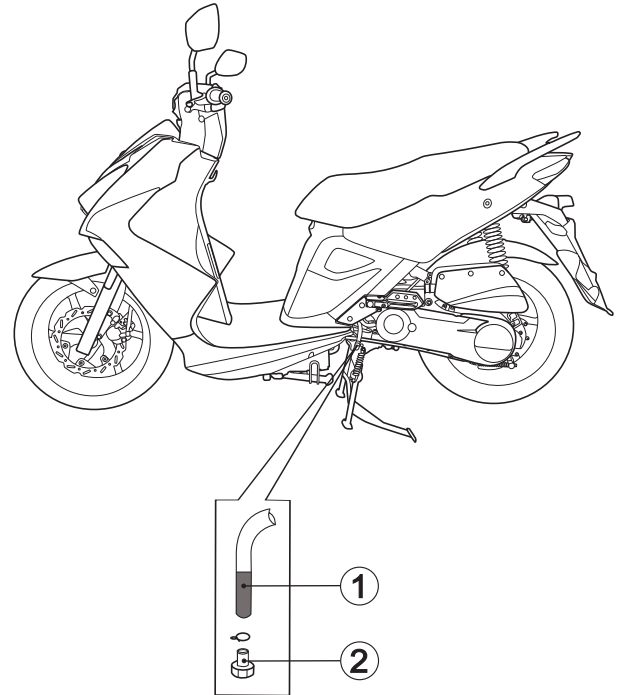

■ **NOTE:** Drain frequently if you often ride in the rain, at full throttle, or the vehicle has been overturned. Follow the oil disposal regulation.

# MAINTENANCE

## Storage

Take necessary steps to be in good condition for next use after long storage.

- Perform any necessary periodic maintenance or repairs before storage
- Exchange new oil after warming up the engine.
- Empty the fuel tank and make sure no fuel remaining by idling until the engine stalls.
- Remove the battery and keep from direct sunlight or freezing temperature, it's better to do a slow charge once a month.
- Wash and dry the vehicle thoroughly
- Apply corrosion inhibitor to all unpainted metal.
- Inflate all tires to the rated pressure and put the wheel stands to raise tires off the ground.
- Cover the vehicle, store indoors and keep dry.

## Removal from Storage

- Remove cover from the vehicle
- Check the battery voltage or charge it if necessary, and then install it in the vehicle.
- Fill the fuel tank with fuel.
- Check all the points listed in the Pre-ride Inspection section.



## WARNING

Gasoline is easily flammable and explosive. It's possible to get burned, even seriously injured when fueling with carelessness.

Stop the engine and keep away from any heat source, spark fire, and flames.

Be sure to add fuel outdoors and wipe the spill up at once.



# EMISSION CONTROL

## **Crankcase Emission Control System**

The scooter is equipped with a closed crankcase system. Blow-by gas is recycled into the combustion chamber via the intake system. This arrangement is to prevent blow-by gas from spreading to the atmosphere.

## **Exhaust Emission Control System**

The exhaust emission from the scooter is controlled by combustion management, fuel delivery, ignition setting and exhaust system. The exhaust system also includes the catalytic converter in the muffler.

## **Evaporative Emission Control System**

The evaporative emission control system is used to prevent gasoline vapors from escaping into the atmosphere from the fuel tank and fuel system.

## **Noise Exhaust Emission Control System**

The engine, intake and exhaust systems of the scooter are designed to comply with federal or local noise regulations. Do not modify the intake or exhaust system; this behavior will offend against the noise regulations.



## **WARNING**

Do not adapt any original factory design and setting, which will deteriorate the sound or emission level.





# Super 8 50 SPECIFICATIONS

## Dimensions

Overall length .....	2040 mm
Overall width.....	735 mm
Overall height .....	1100mm
Wheel base.....	1365mm
Seat height .....	790 mm
Dry weight.....	120 kg

## Capacities

Engine oil (exchange).....	0.7 L
Transmission oil (exchange).....	0.18L
Fuel tank .....	6.0 L
Maximum weight capacity .....	270kg

## Engine

Type .....	Four-stroke, air-cooled OHC
Displacement.....	50 cc
Bore and stroke.....	39 X 41.4 mm
Compression ratio .....	10.5:1
Spark plug .....	CR7HSA
Idle speed .....	2000 RPM
Cooling system .....	Forced Air
Max Horsepower.....	2.5kW/7000rpm
Max Torque.....	3.3Nm/6000rpm
Starting system .....	Electric starter motor

## Chassis

Tire size, front.....	120/70-14
Tire size, rear.....	120/80-14
Brake (front) .....	DISC
Brake (rear) .....	DRUM

## Electrical

Ignition type .....	ECU
Battery .....	12V 8Ah
Headlight .....	12V 21W/41.5W
Tail/brake light .....	12V 2.1W/12V 3.1W
Front turn signal light .....	12V 10W
Rear turn signal light .....	12V 1.9W
Position light.....	12V5.5W
Fuses .....	15A*1, 10A*1, 7A*1